



Wap Super 1300

Wap Super 1860

Wap Super 2000

Betriebsanleitung mit Ersatzteilliste
Instructions de Service avec Liste des Pièces de Rechange
Operating Instructions with Spare Parts List
Gebruiksaanwijzing met onderdelenlijst

Maschinen-Nummer
Machine No.
Machine No.
Machine Nummer _____

15719
040290

9. Ersatzteilliste/Spare List/Onderdelenlijst

Änderungen im Zuge technischer Neuerungen vorbehalten!
Subject to changes due to technical innovations!
Constructiewijzigingen vorbehalten!

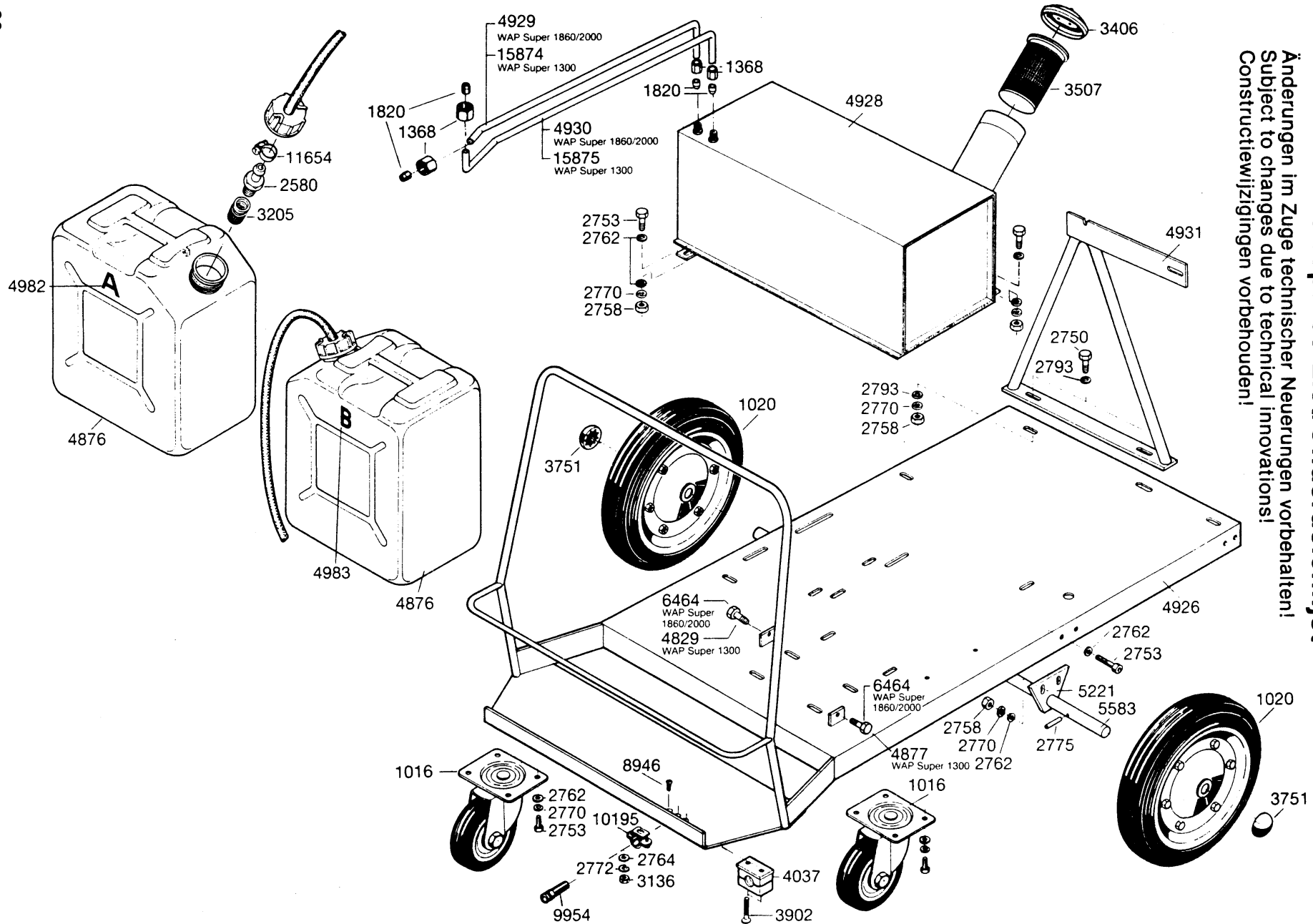

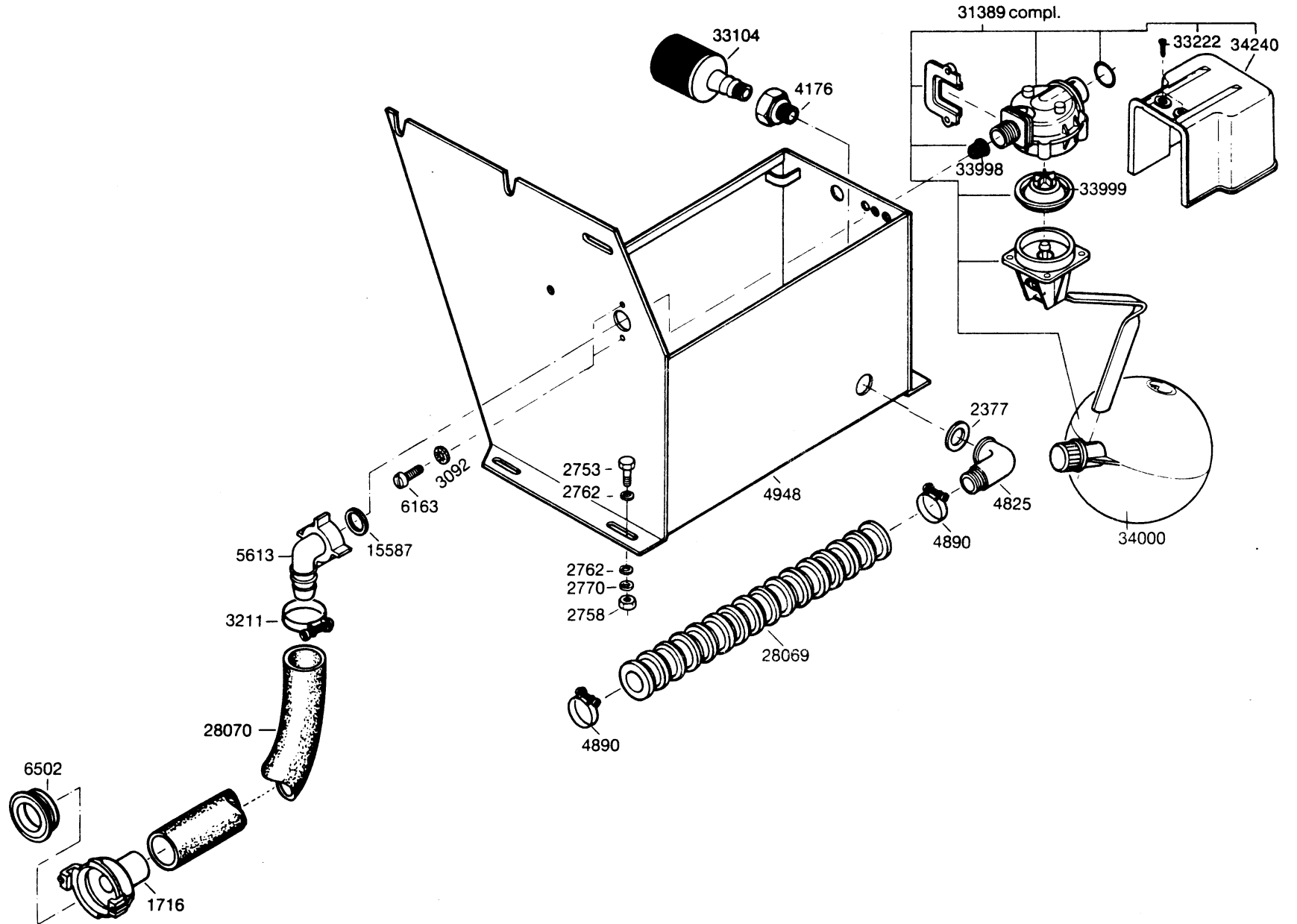

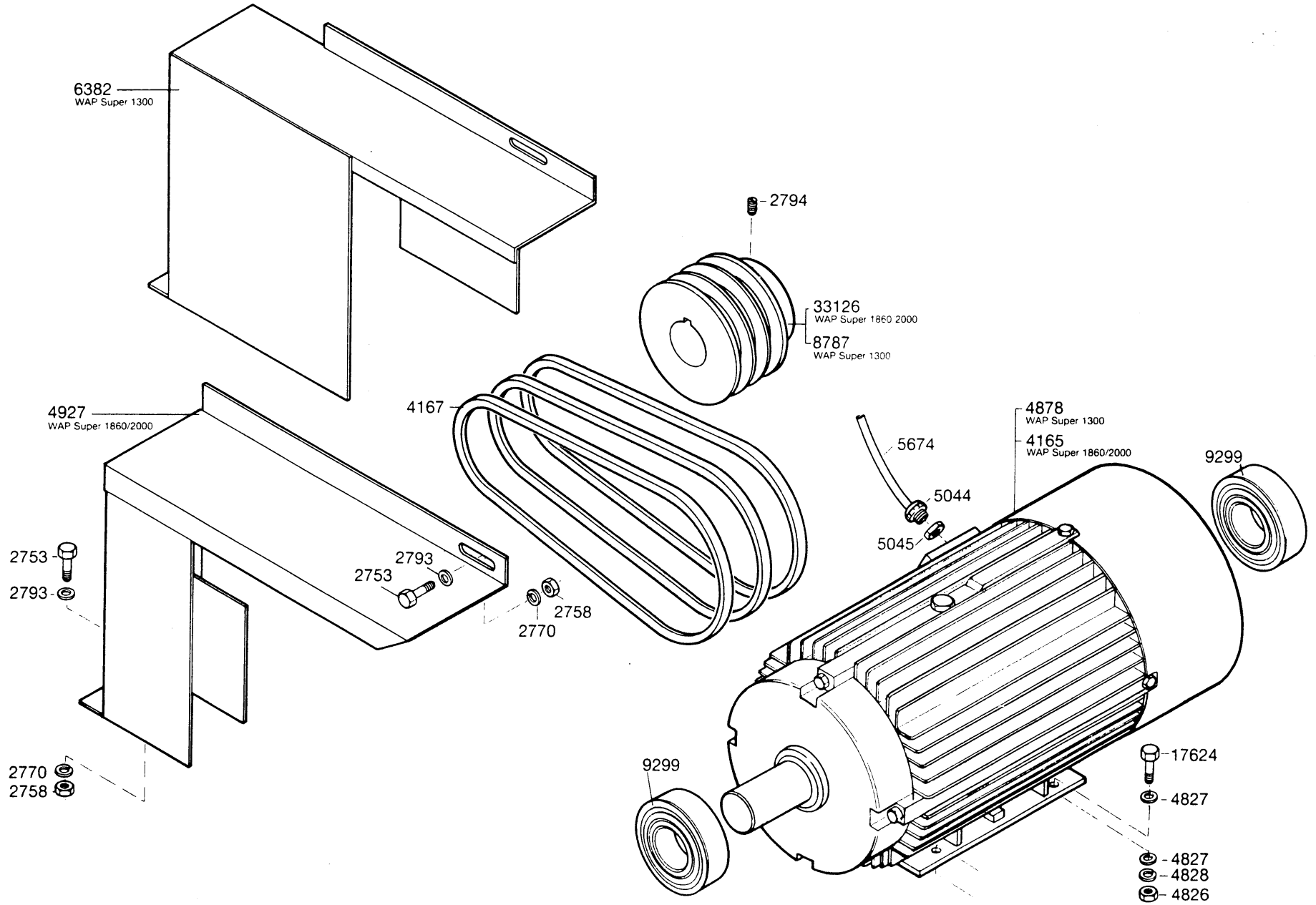

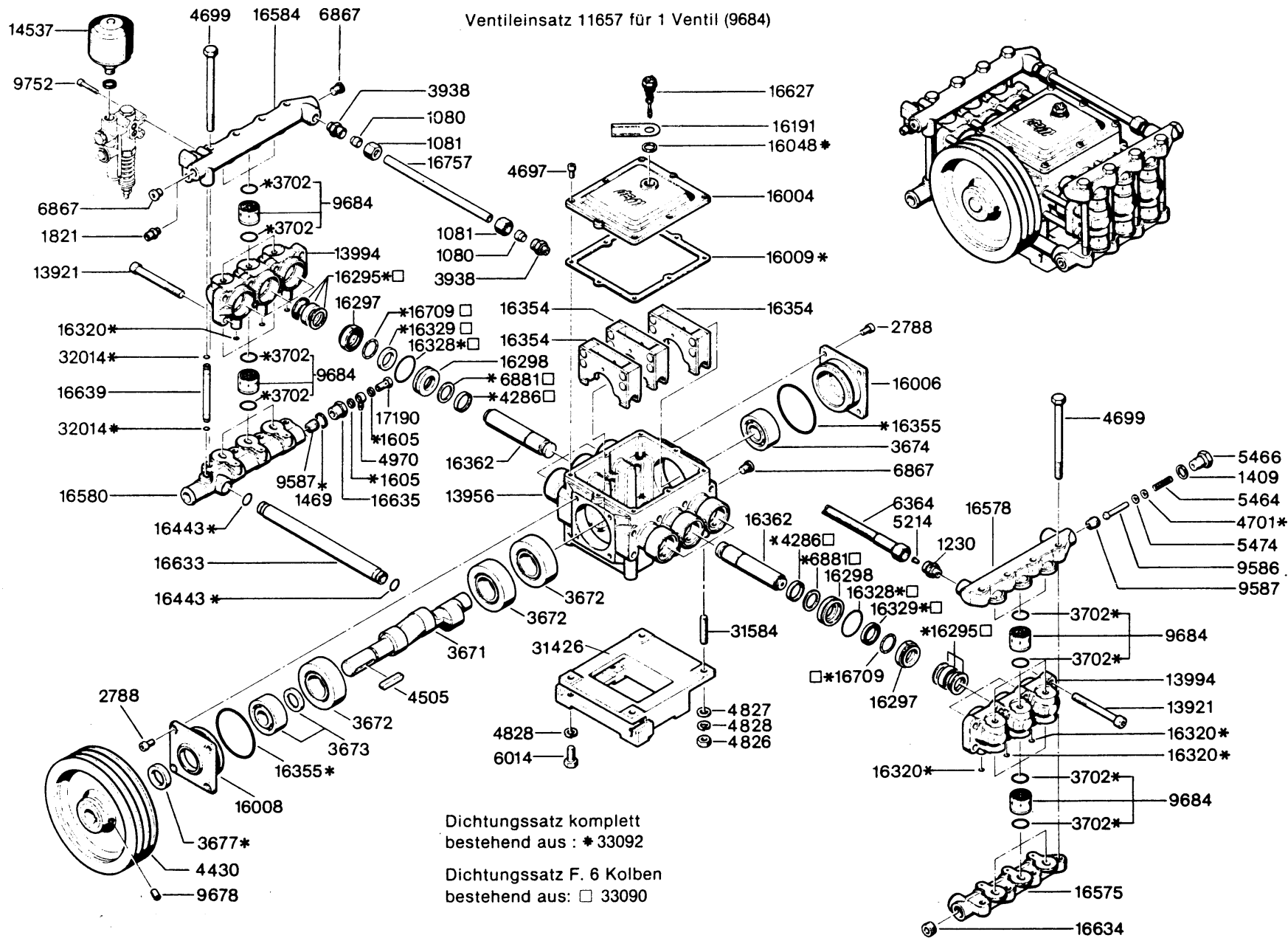

Ventileinsatz 11657 für 1 Ventil (9684)

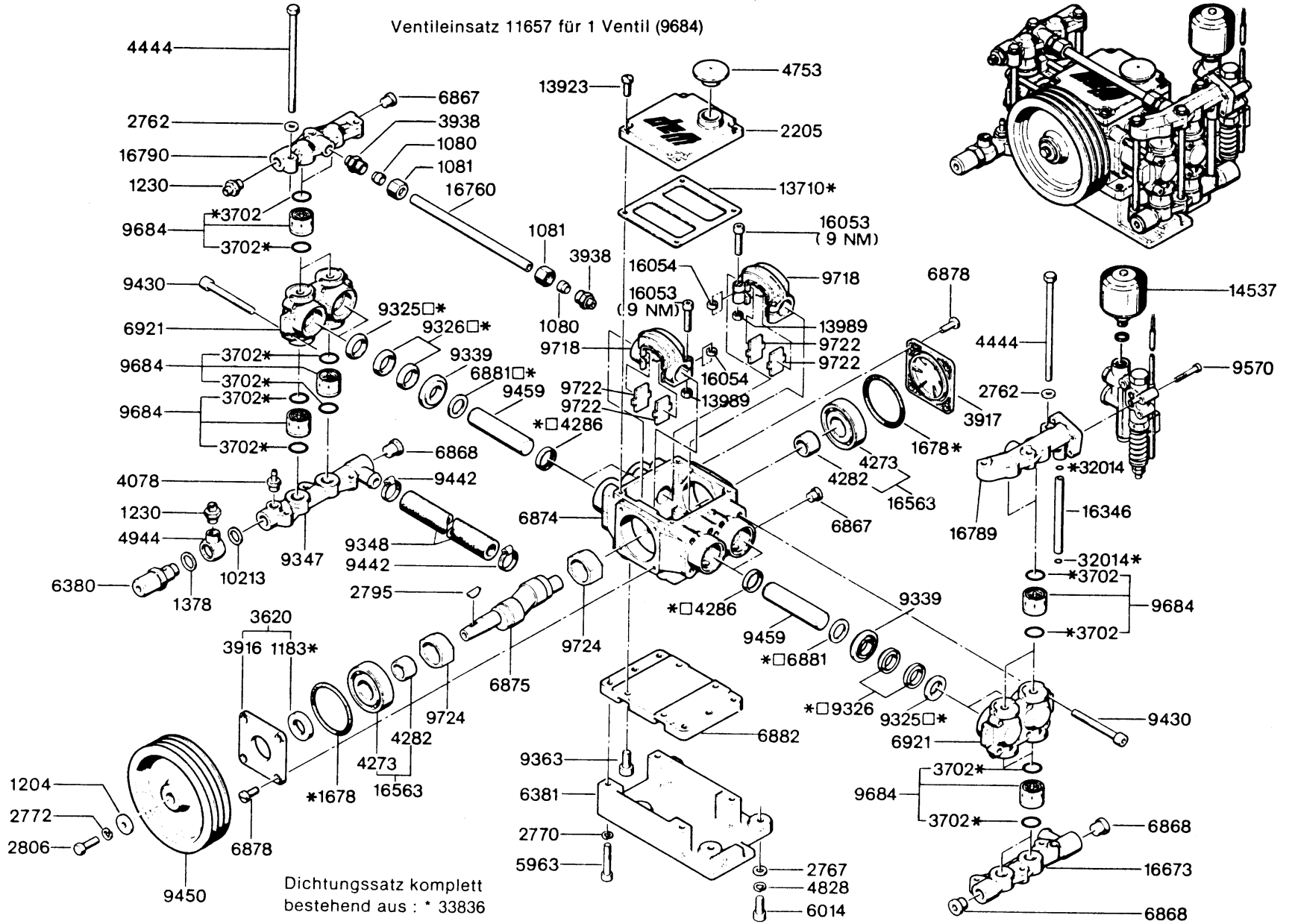

Dichtungssatz komplett
bestehend aus : * 33836

Dichtungssatz F. 4 Kolben
bestehend aus: □ 11746

Pumpe WAP Super 1300

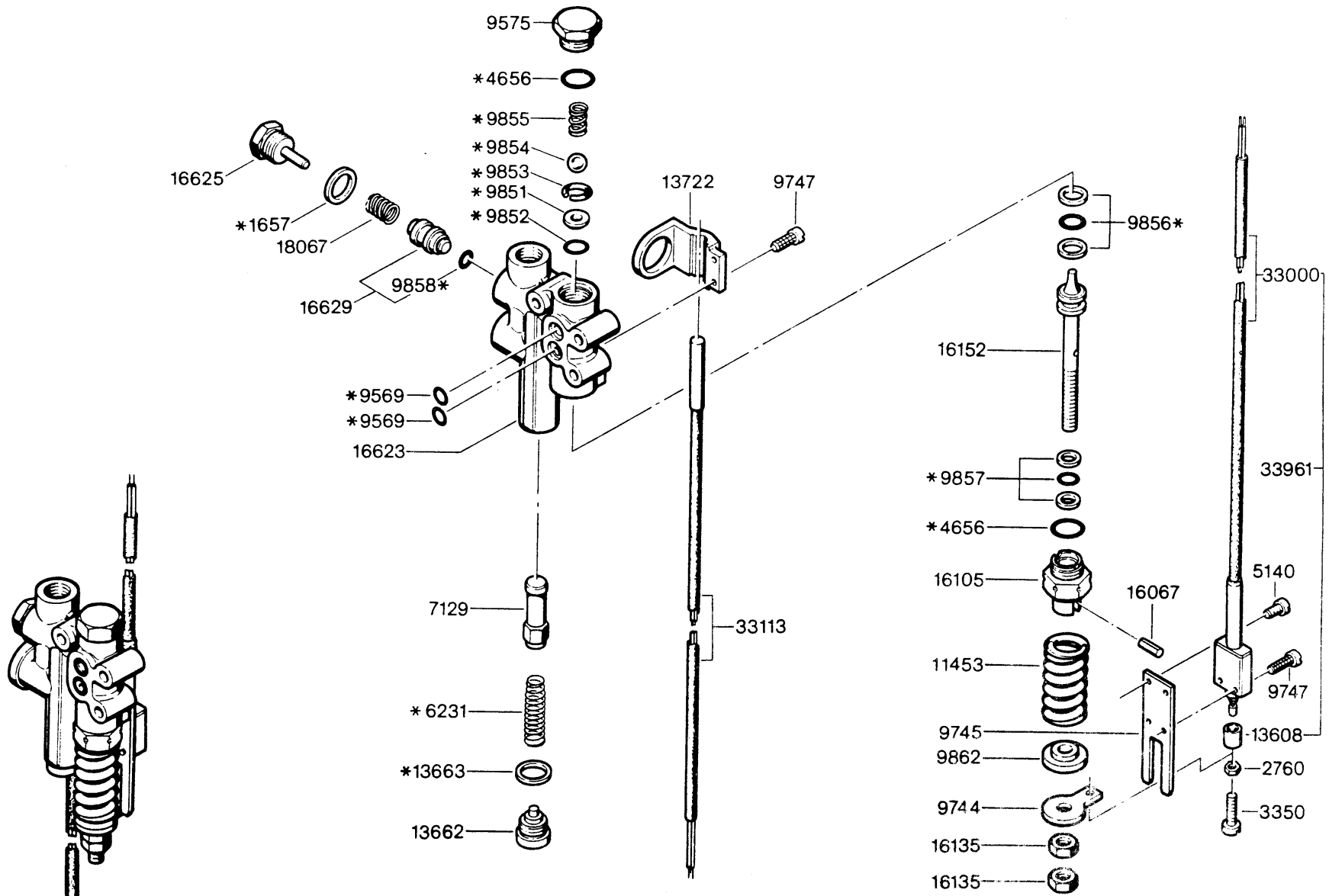

Dichtungssatz komplett
bestehend aus: *15151

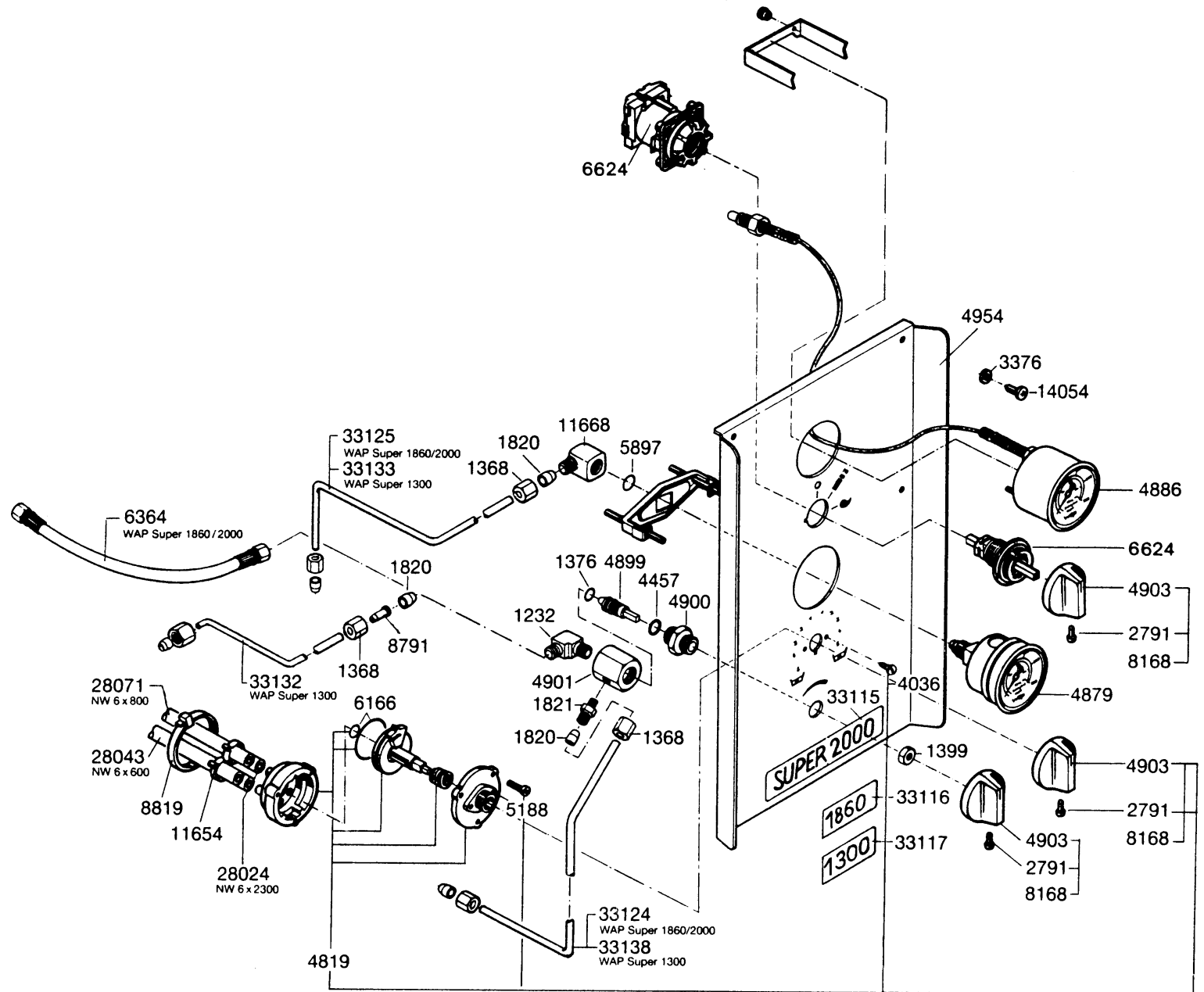

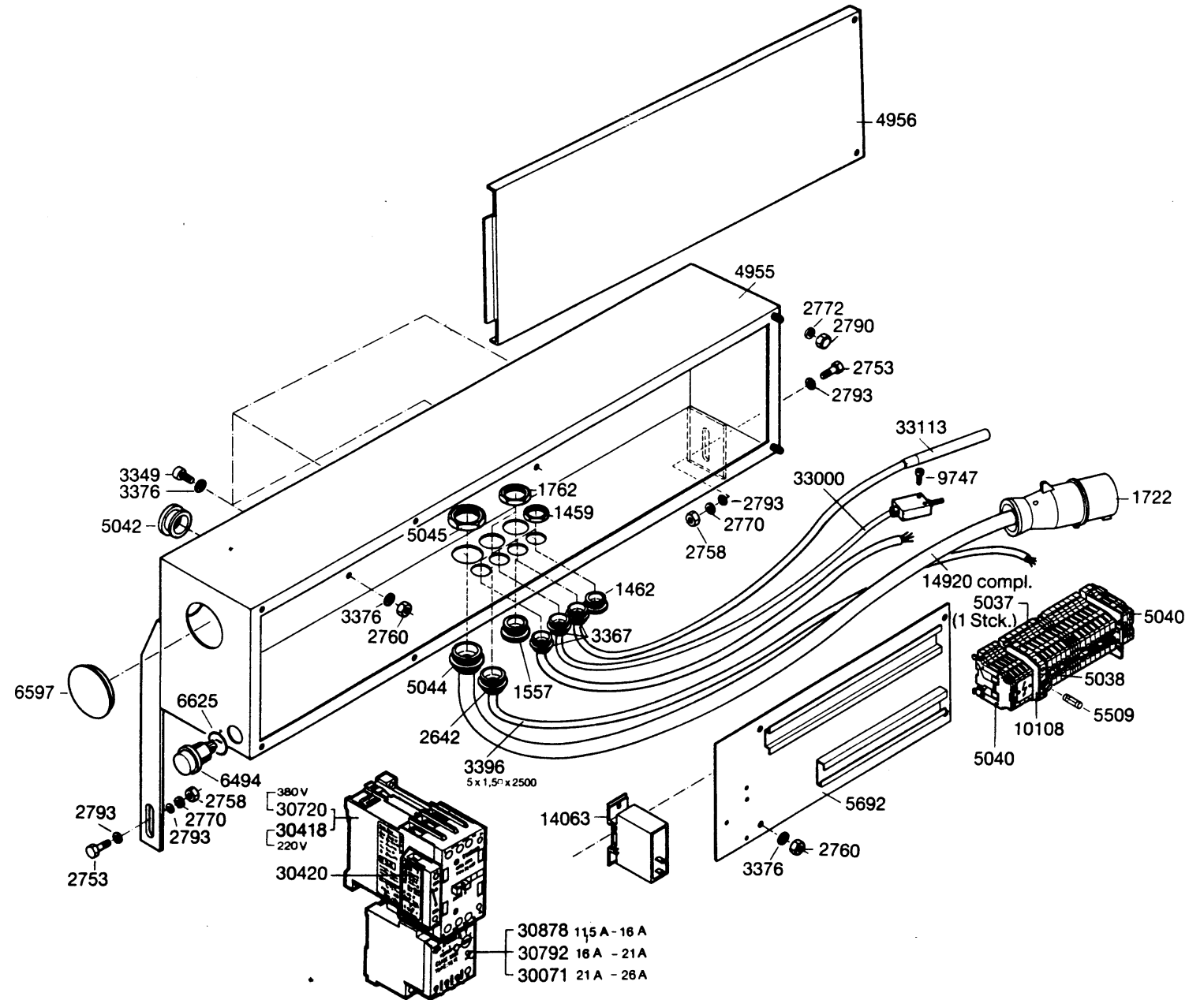

WAP Super 1300

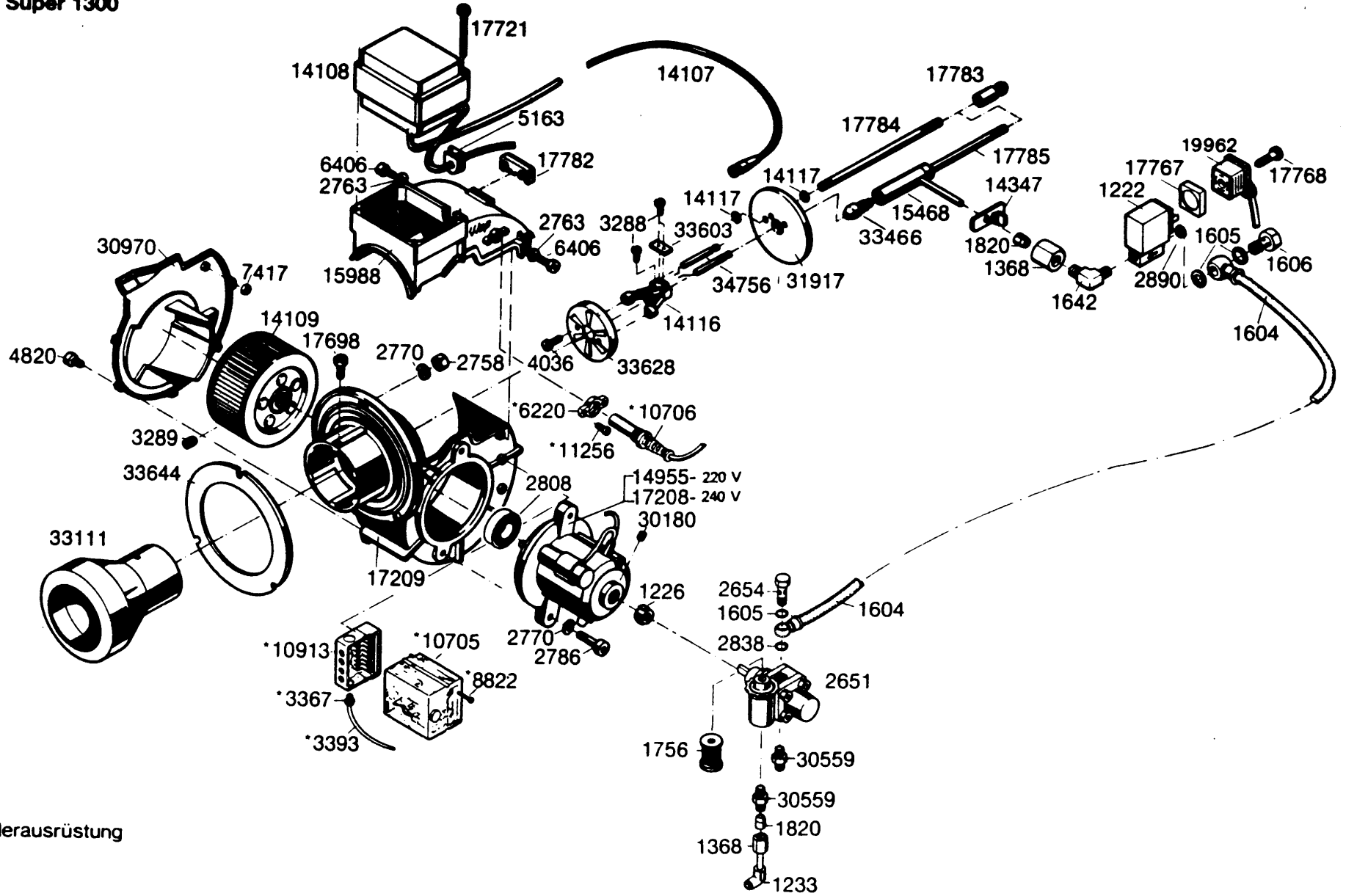

* Sonderausrüstung

WAP Super 1860
WAP Super 2000

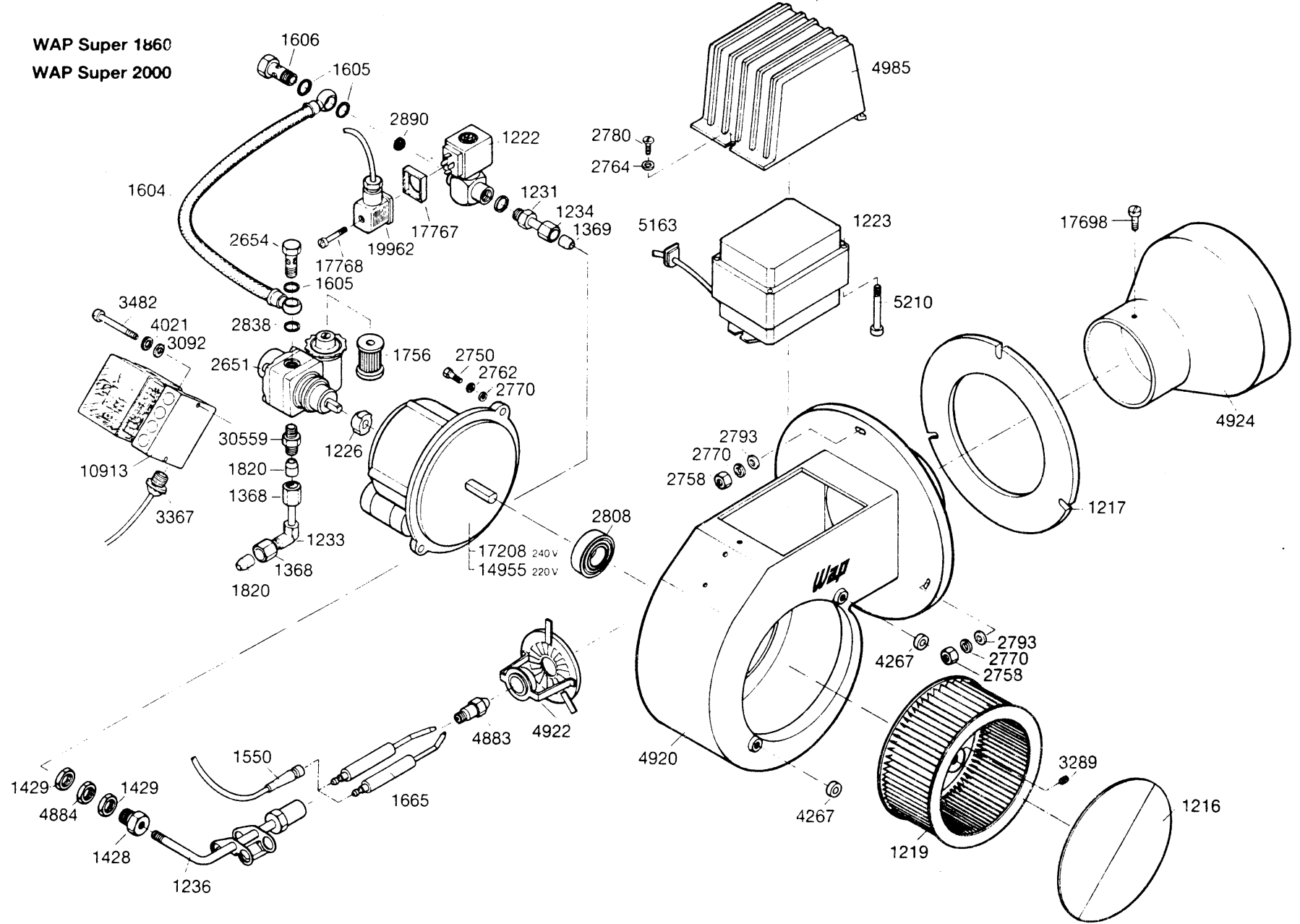

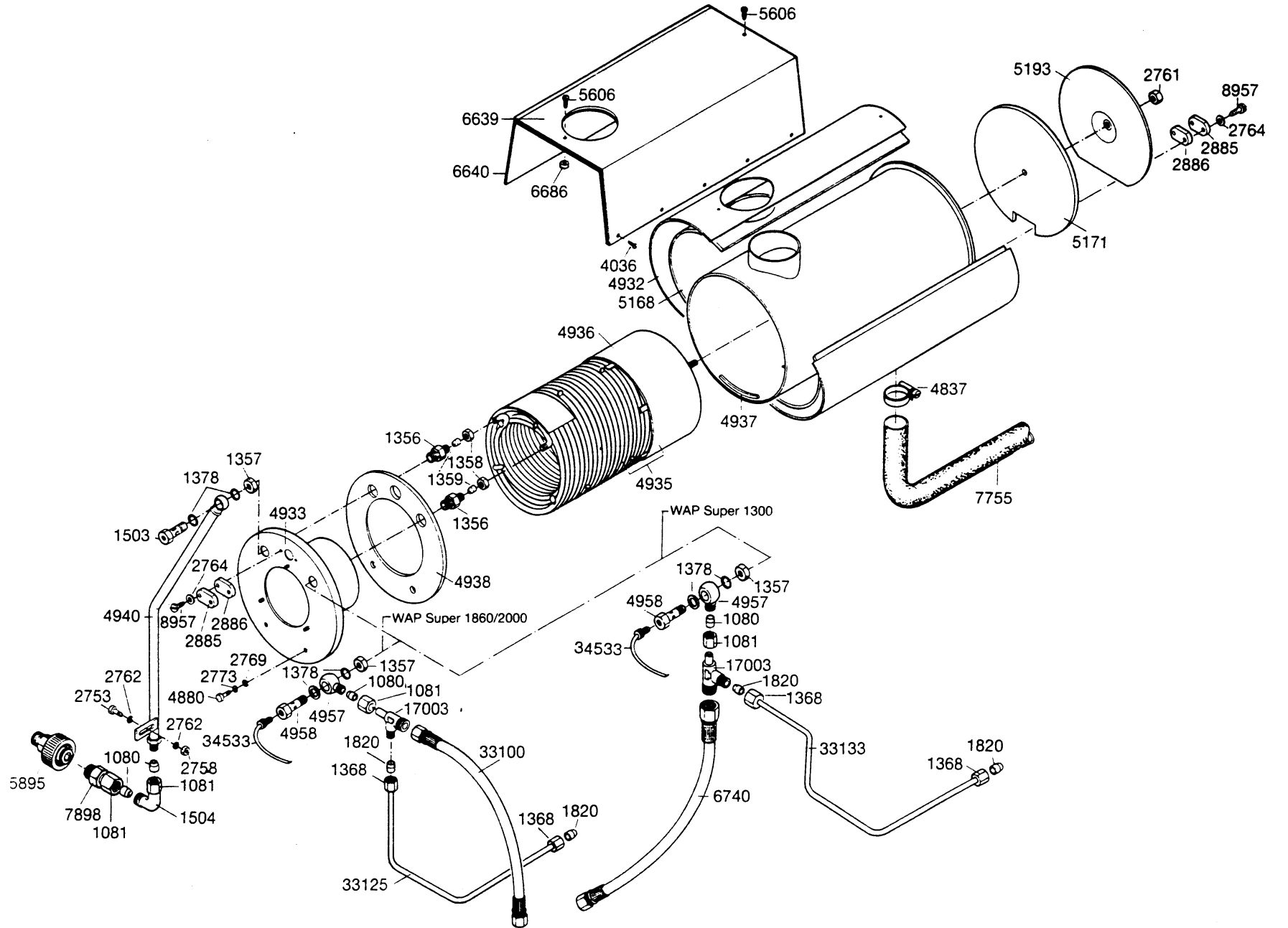

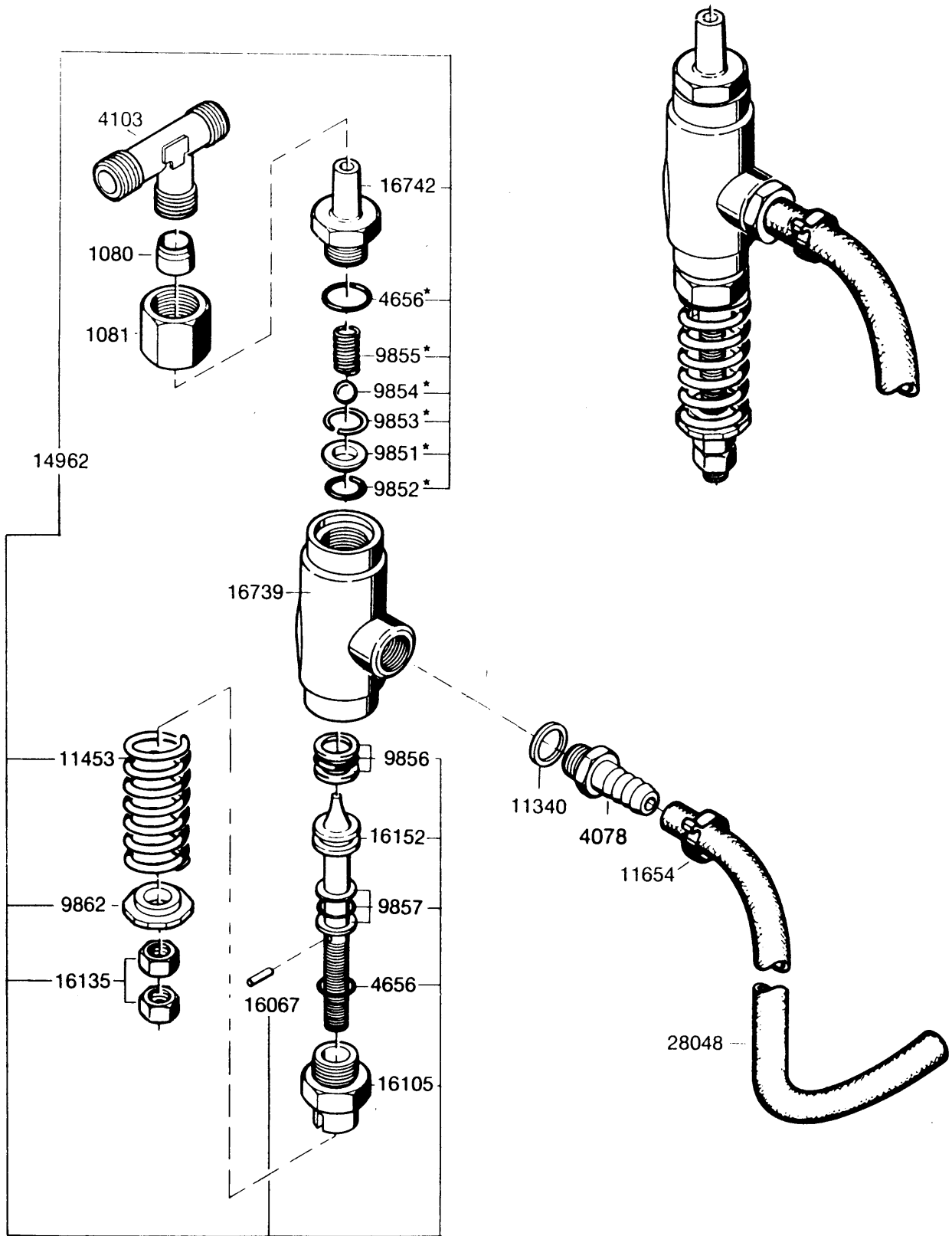

Dichtungssatz kpl. bestehend aus: * 15518

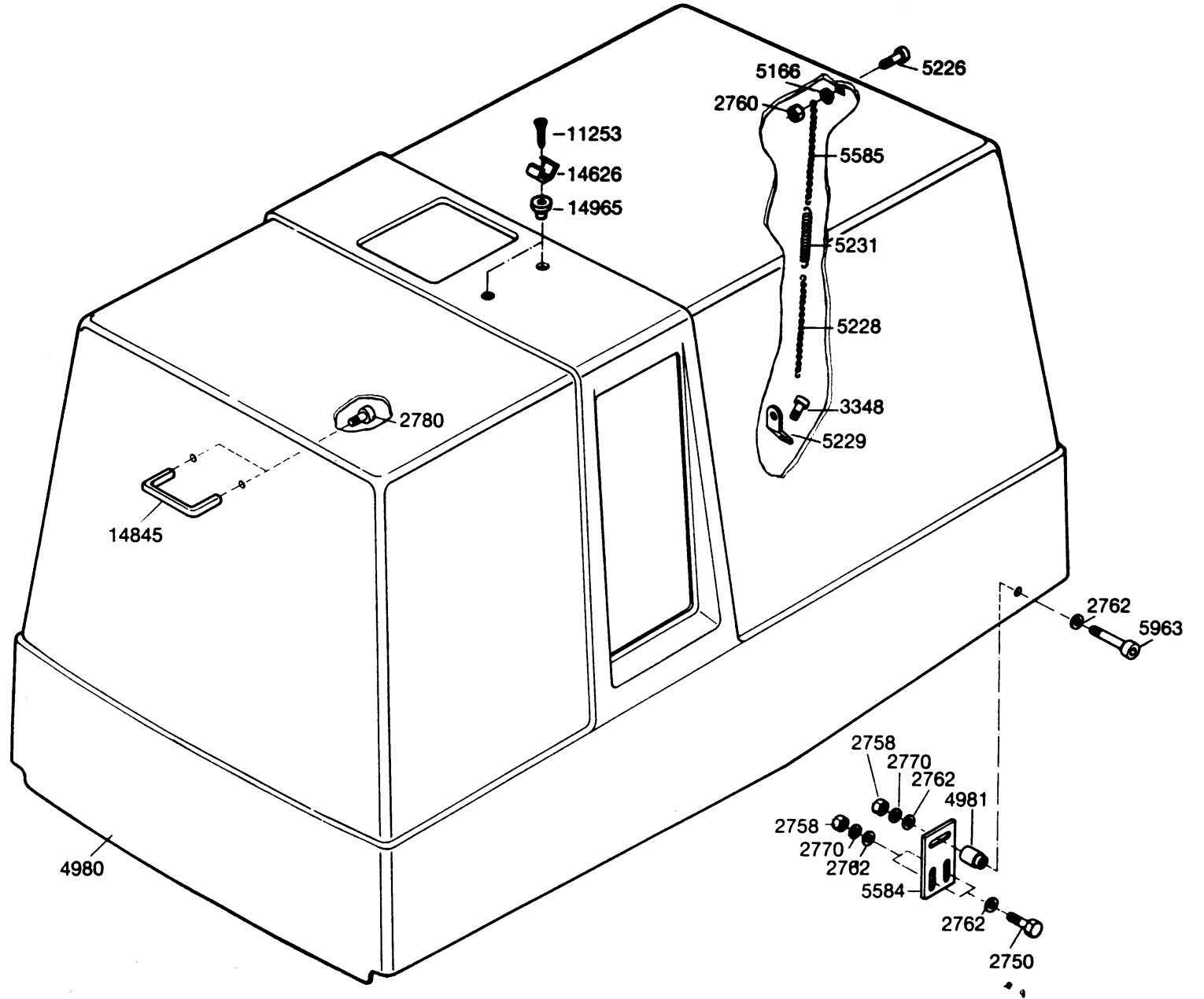

HD - Düsen siehe Düsentabelle

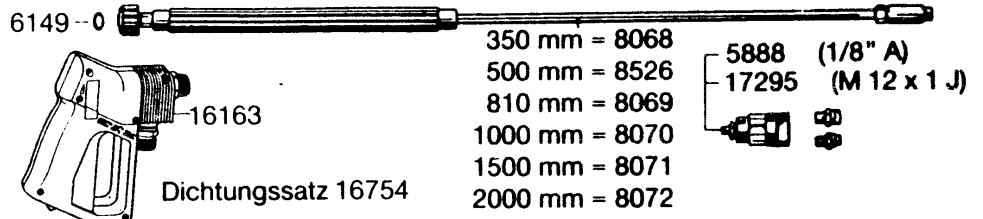
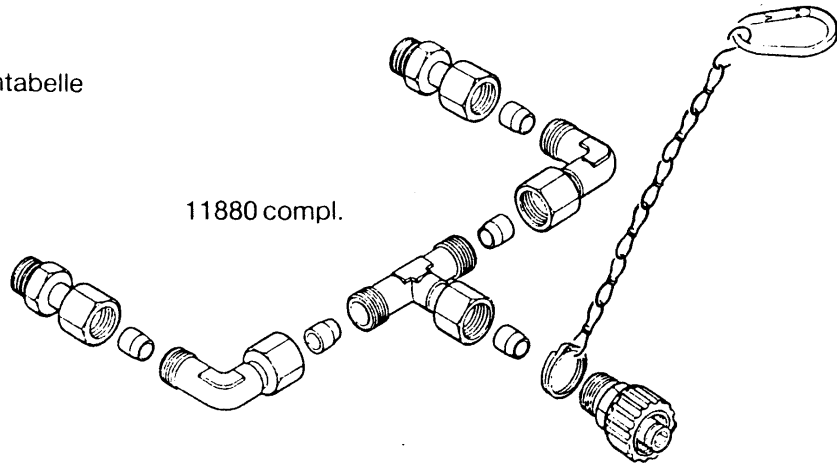

- Ø 0,9 = 15834
- Ø 1,0 = 11328
- Ø 1,1 = 4875
- Ø 1,2 = 5567
- Ø 1,4 = 5477

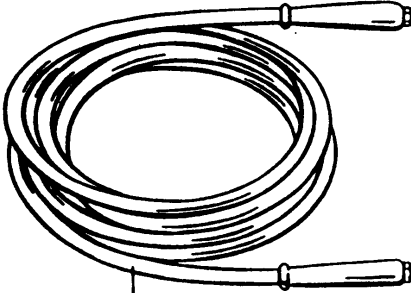
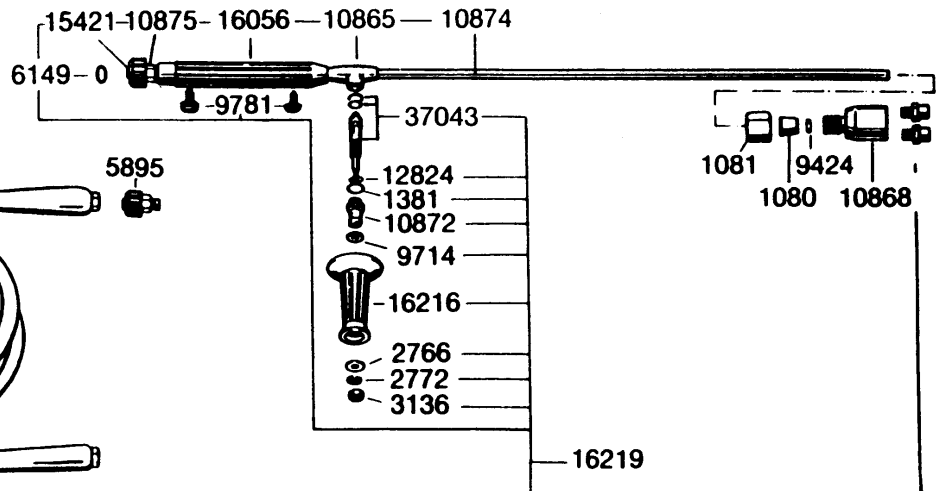
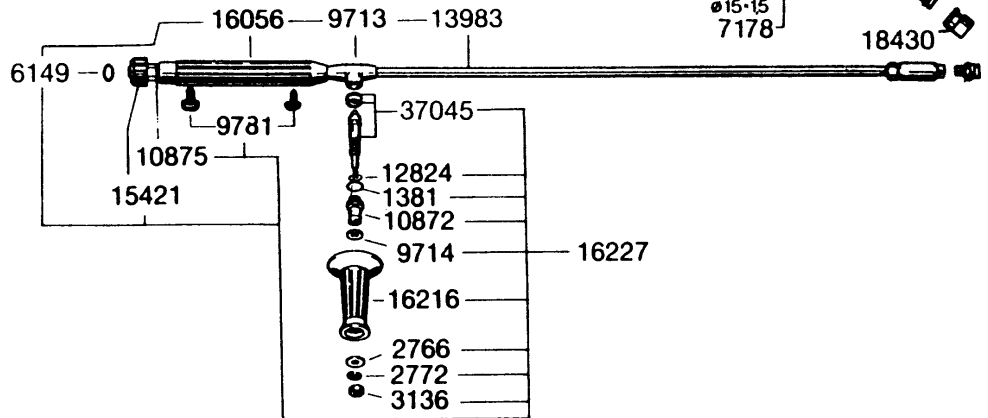
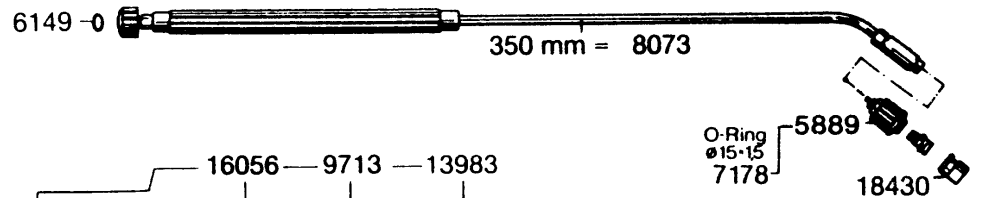

- 7826 NW 10 x 50 m
- 1476 NW 10 x 20 m
- 1475 NW 10 x 15 m
- 1473 NW 10 x 10 m

8. Schaltpläne Wiring Diagrams Schakelschema

Geräteliste — gültig für alle Schaltpläne

Please note: The list of appliances is valid for **a l l** wiring diagrams

machinelijst — voor alle schakelschema's

Kennbuchstabe	Geräteart
A 1	Klemmkasten
B 1	Combistat bzw. Thermostat
B 3	Thermosicherung
C 1	Entstörkondensator (nur Schweiz)
F 1	Motorschutzrelais
F 2	Steuersicherung (Sicherung 6,3 A)
F 3	Druckschalter (Druckwächter nur Schweiz)
F 4	Strömungswächter
F 5	Sicherungsautomat
K 1	Schütz Motor Pumpe
K 2	Zeitrelais (Verzögerung Heizölzufuhr)
K 1/K 3/K 4/K 5	Stern-Dreieck-Kombination
M 1	Motor Pumpe
M 2	Motor Brenner
P 1	Betriebsstundenzähler (Sonderzubehör)
Q 1	Hauptschalter
S 1	Ausdampftaster
T 1	Zündtrafo
X 1	Anschlußklemmenleiste
Y 1	Magnetventil (Heizölzufuhr)

A 1	Raccordement
B 1	Thermostat
B 2	Thermofusible
F 1	Relais de sûrintensité
F 2	Fusibles (6,3 A)
F 3	Interrupteur de pression
F 4	Senseur de débit
F 5	Fusible automatique
K 1	Contacteur pompe-moteur
K 2	Relais temporisé
K 1/K 3/K 4/K 5	Combinaison en étoile
M 1	Moteur de la pompe
M 2	Moteur du brûleur à mazout
P 1	Compteur d'heures
Q 1	Interrupteur général
S 1	Contact évacuation vapeur
T 1	Transformateur d'allumage
X 1	Bornes
Y 1	Electro-vanne (alimentation mazout)

Symbol	equipment (appliance)
A 1	terminal box
B 1	combistat respectively thermostat
B 3	thermal cutout
F 1	overload relay
F 2	fine-wire fuse (6.3 A)
F 3	pressure switch
F 4	low water cutoff
F 5	automatic cutout
K 1	contactor motor pump
K 2	time relay (slowing down fuel oil supply)
K 1/K 3/K 4/K 5	star delta combination
M 1	electric motor pump
M 2	electric motor burner
P 1	working hour meter (special accessory)
Q 1	main switch
S 1	steam release button
T 1	ignition transformer
X 1	connector block
Y 1	solenoid valve (fuel oil supply)

Kenletter	Onderdeel
A 1	Aansluitkast
B 1	Thermostaat
B 3	Thermozekering
C 1	Ontstoringskondensator (uitsl. zwitserland)
F 1	Motorbeveiligingsrelais
F 2	Smeltveiligheid (zekering 6.3 A)
F 3	Drukschakelaar (druksensor uitsl. zwitserland)
F 4	Stromingsensor
F 5	Zekeringsautomaat
K 1	Pomp-motor beveiliging
K 2	Timer (vertraging olietoevoer)
K 1/K 3/K 4/K 5	Ster driehoek combinatie
M 1	Pompmotor
M 2	Brandermotor
P 1	Bedrijfsurenteller (spec. uitv.)
Q 1	Hoofdschakelaar
S 1	Uitdampknop
T 1	Ontstekingstrafo
X 1	Aansluitklemmen
Y 1	Magneetventiel (olietoevoer)

Ausführung BRD, Großbritannien, Niederlande
Version German Federal Republic, Great Britain, Netherlands
Versie Duitse Bondsrepubliek, Groot-Brittannië, Nederland

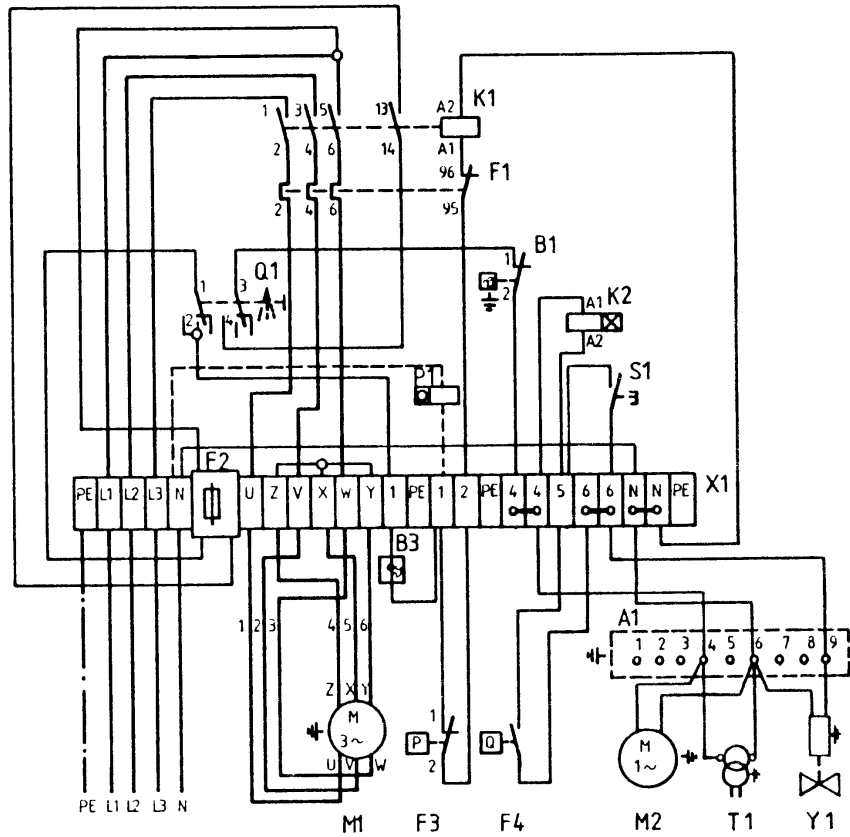

Ausführung Schweiz
Version Switzerland
Versie Zwitterland

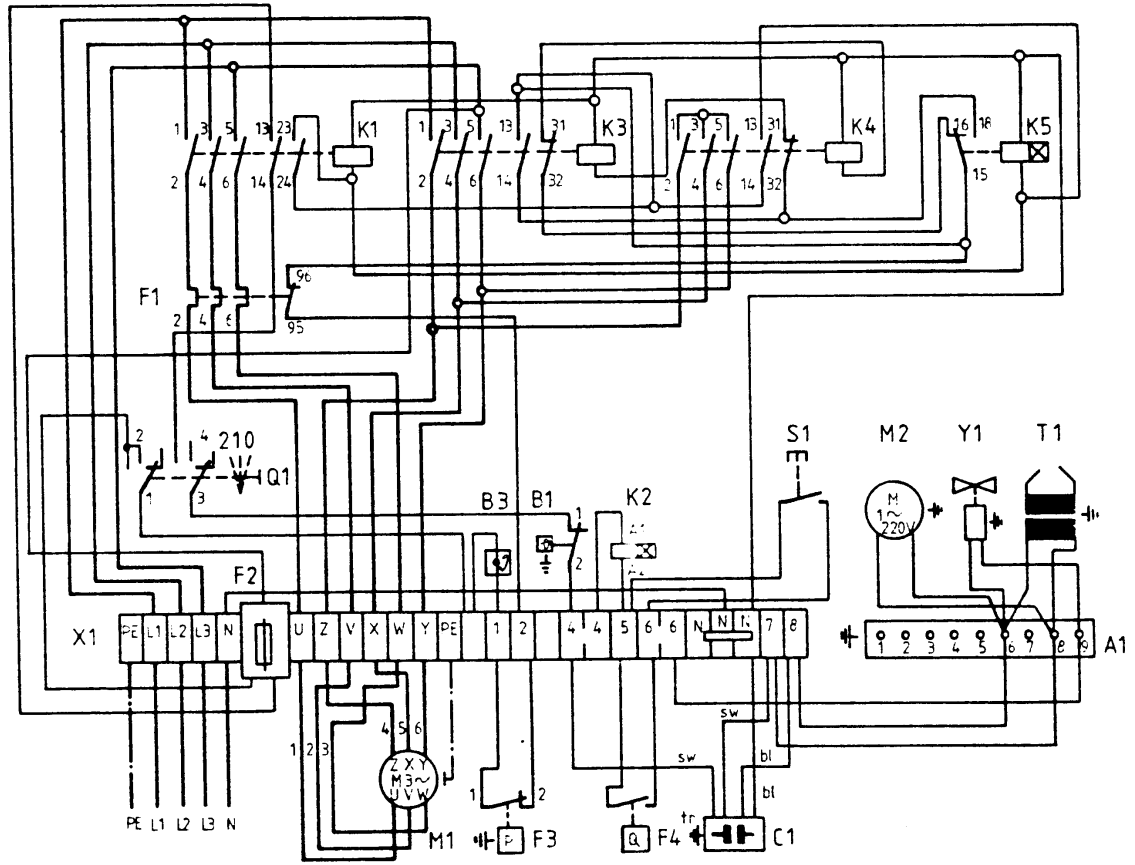

Ausführung Österreich
Version Austria
Versie Oostenrijk

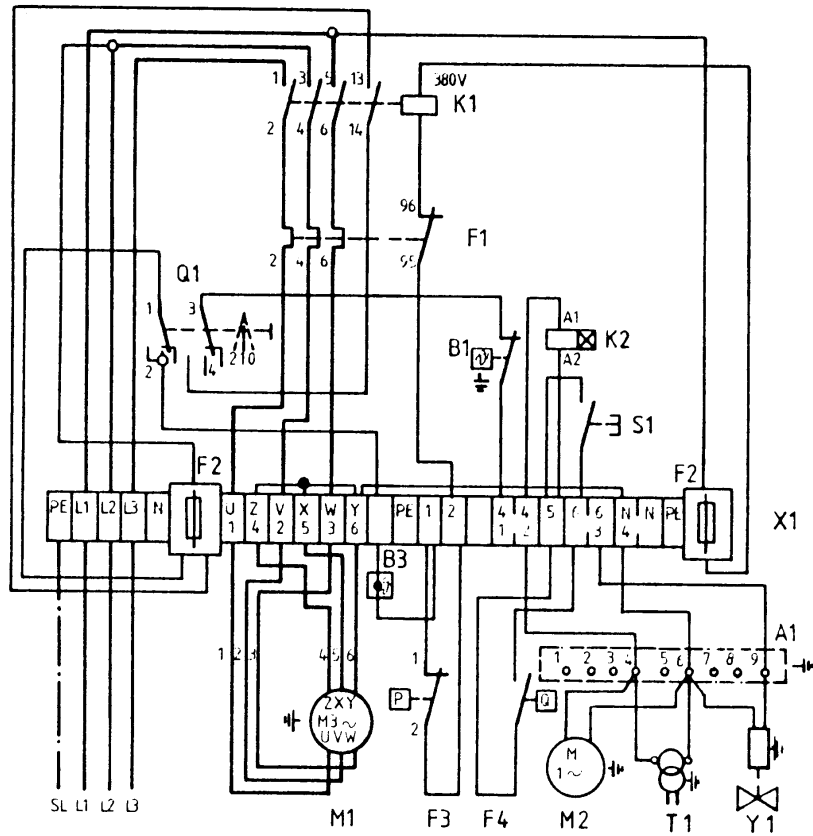

Ausführung Frankreich
Version France
Versie Frankrijk

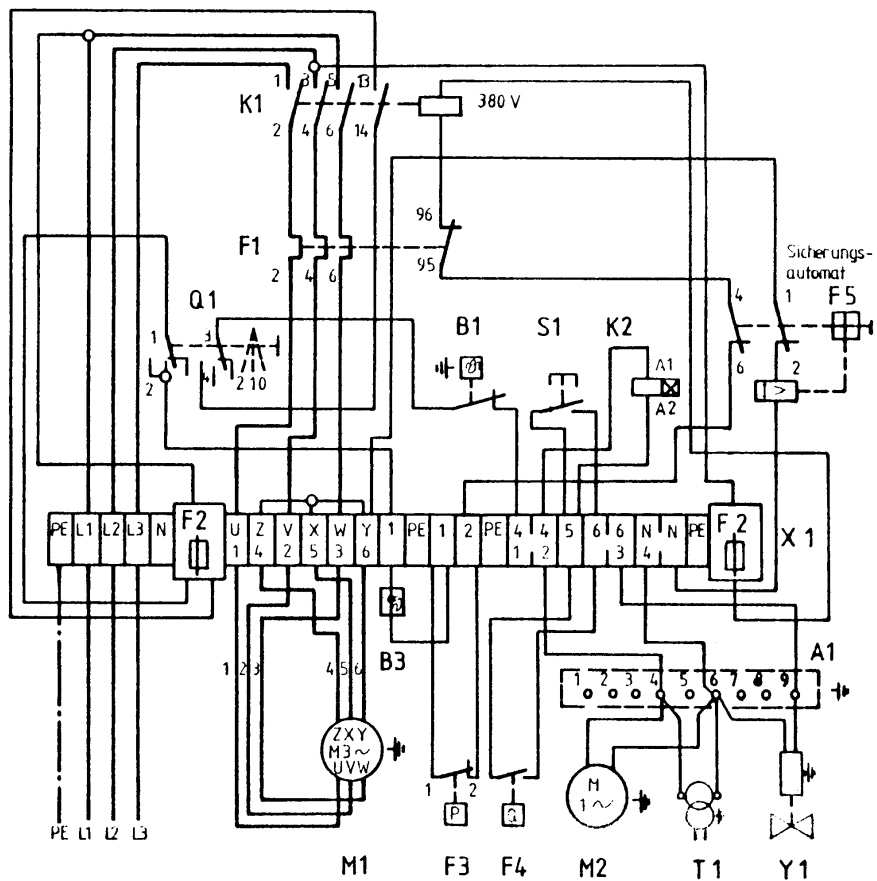

Ausführung Belgien 220 V
Version Belgium 220 V
Versie België 220 V

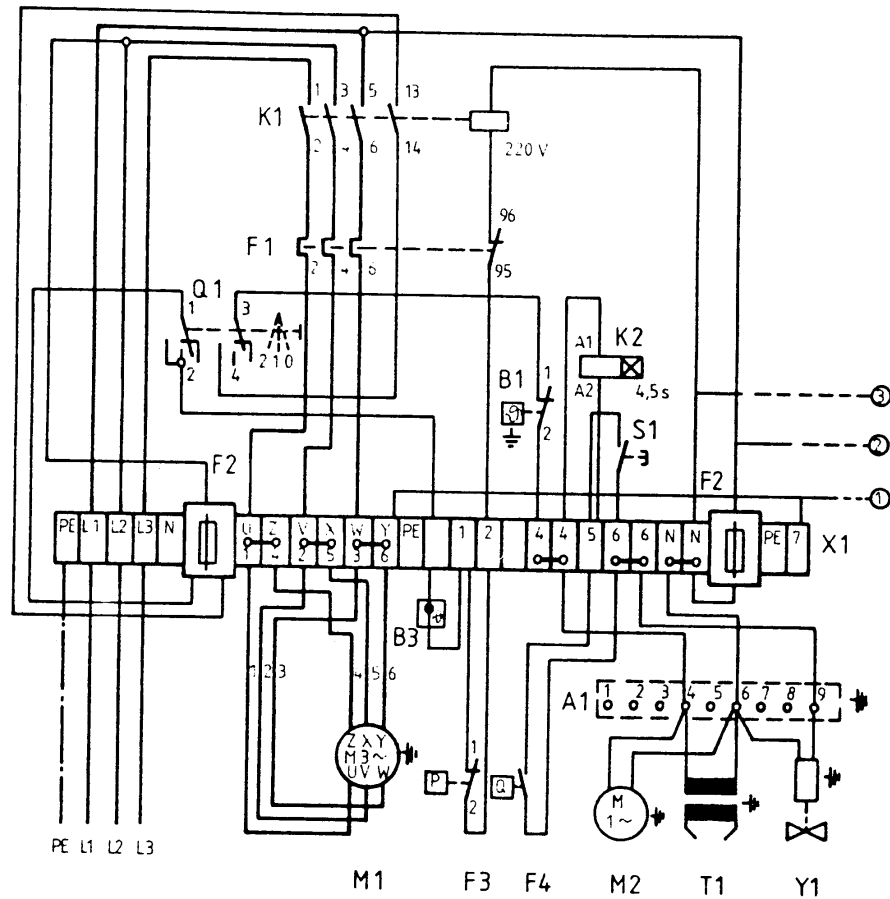

Ausführung Belgien 380 V
Version Belgium 380 V
Versie België 380 V

