



Ersatzteilliste

CS 811 Vario

für Maschinen-Nummer _____

41107
010389

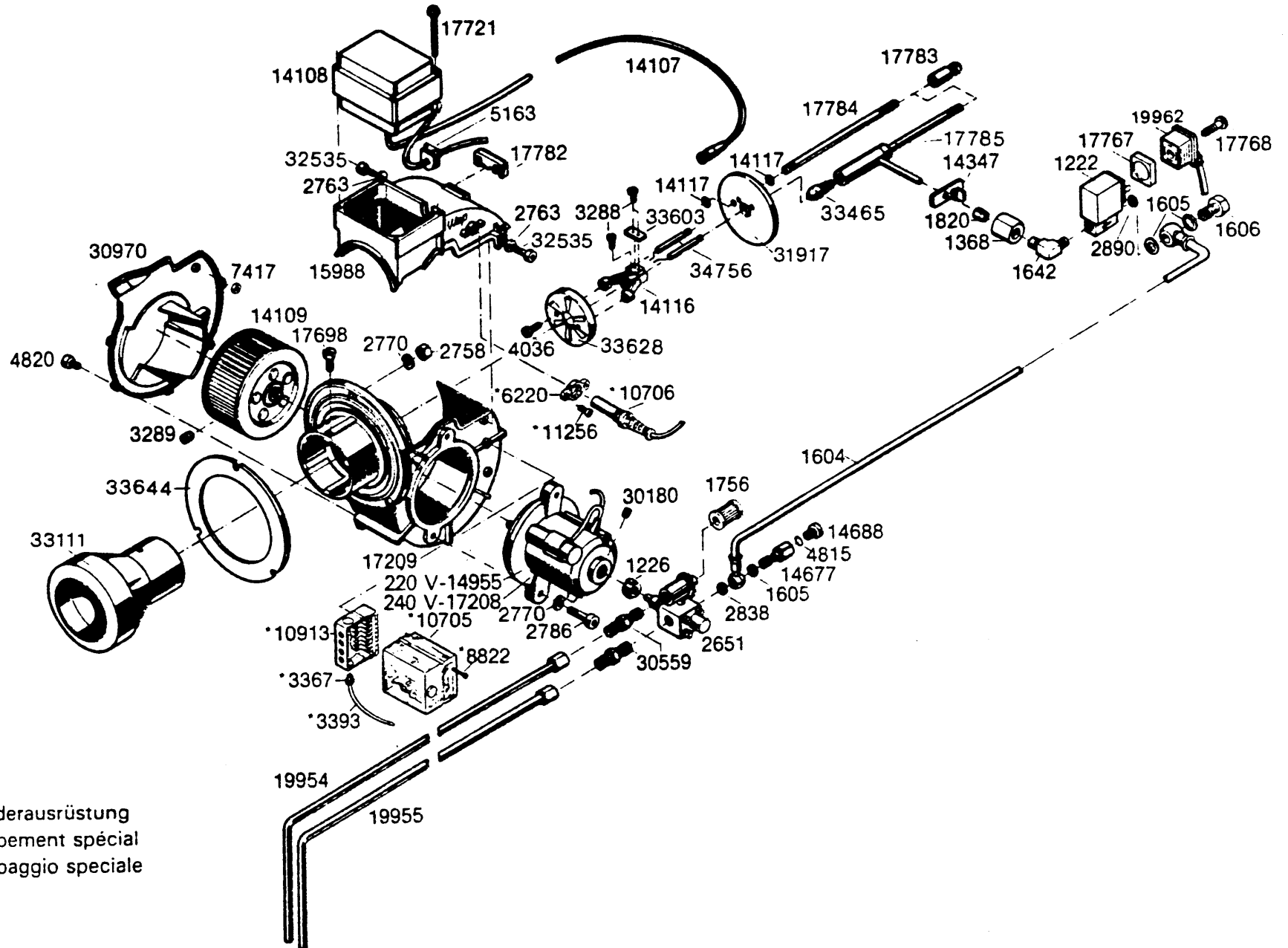

CS 811 Vario \rightleftharpoons CS 630

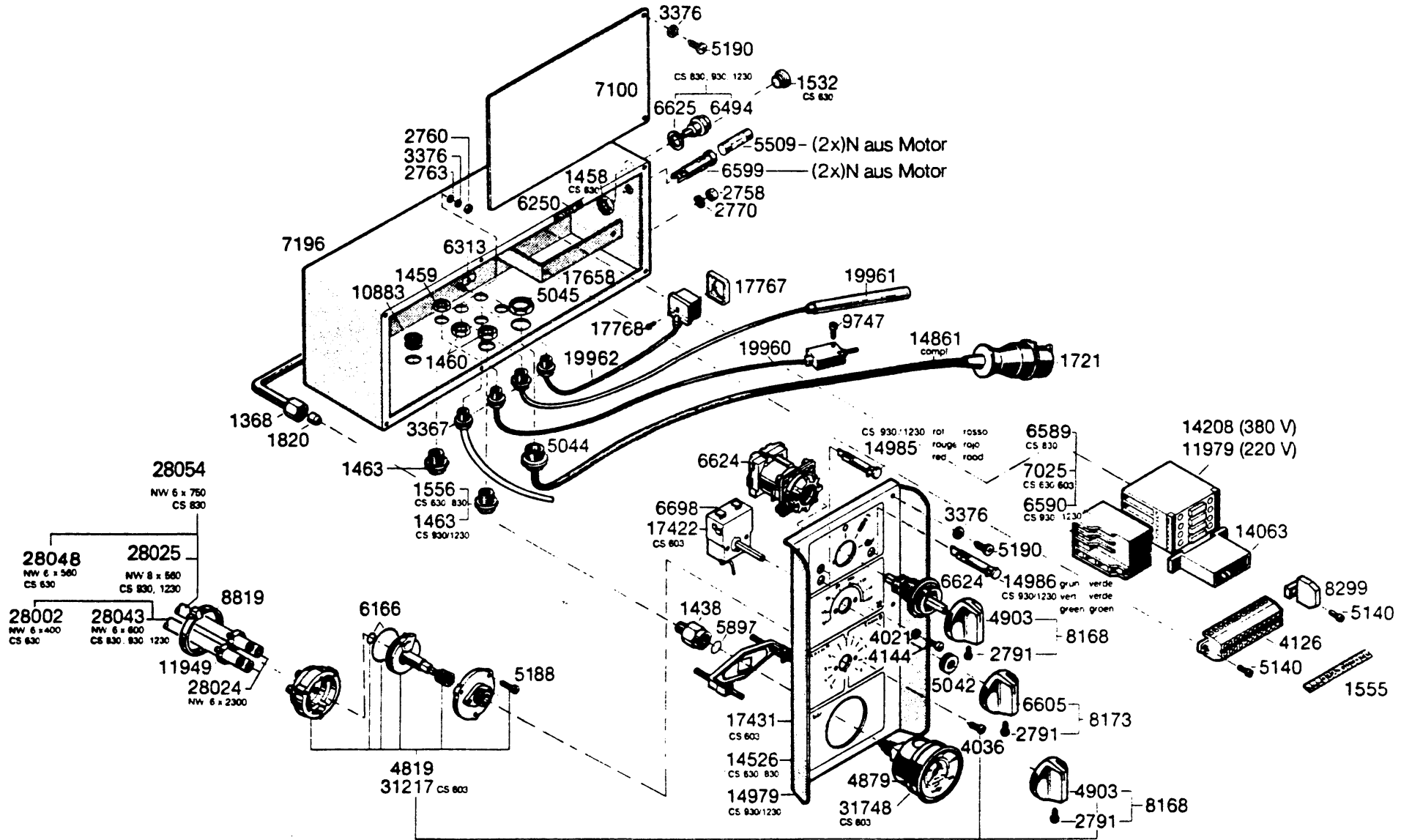

CS 811 Vario \cong CS 630

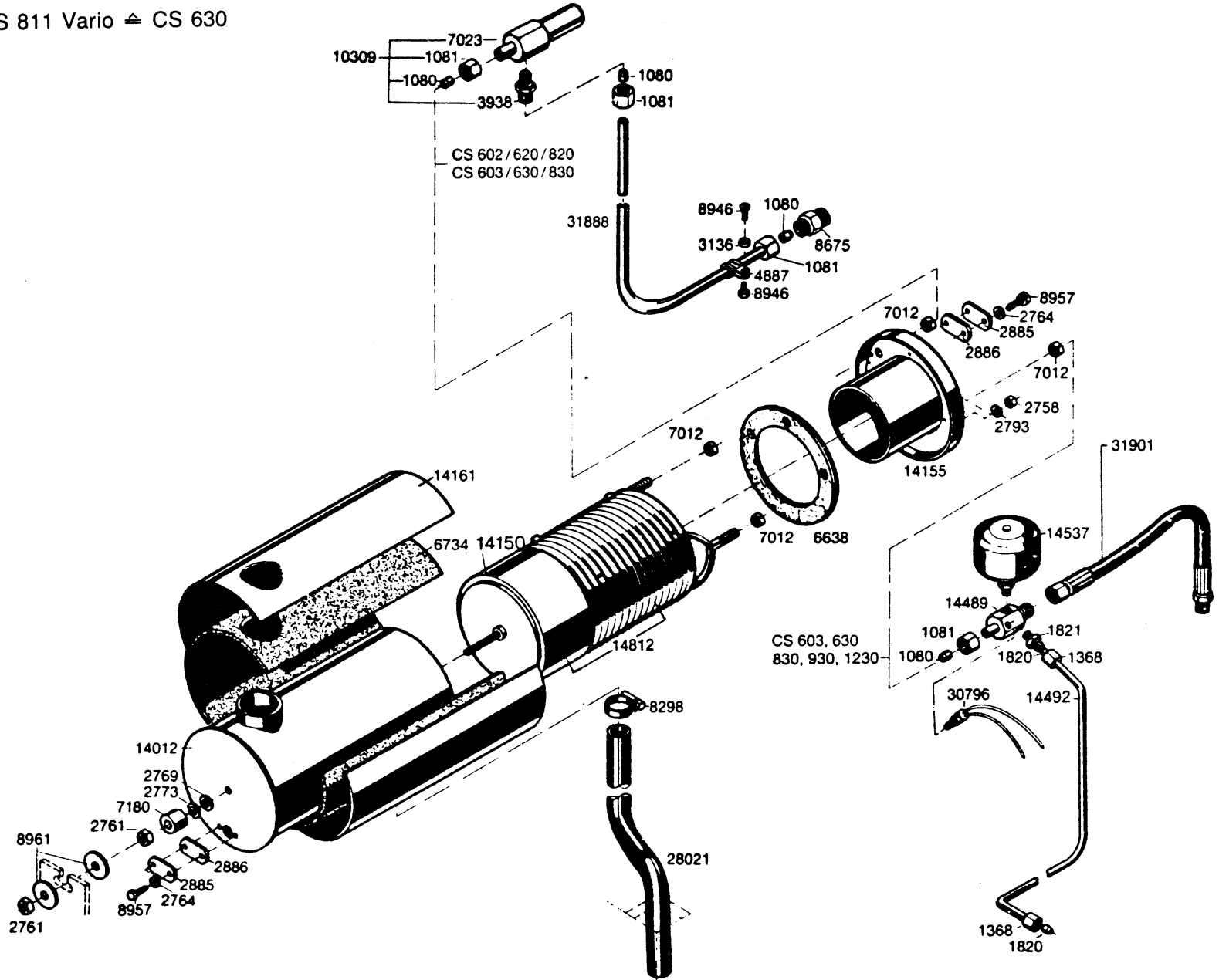

Wap® CS 603 / 630

Dichtungssatz kpl. bestehend aus:

* 15246

jeu de garniture, complet, consistant en:

* 15246

guarnizione, complete, consistuita da:

* 15246

Dichtungssatz Kolben bestehend aus:

□ 11663

jeu de garniture piston, consistant en:

□ 11663

guarnizione pistone, consistuita da:

□ 11663

CS 811 Vario ≅ CS 630

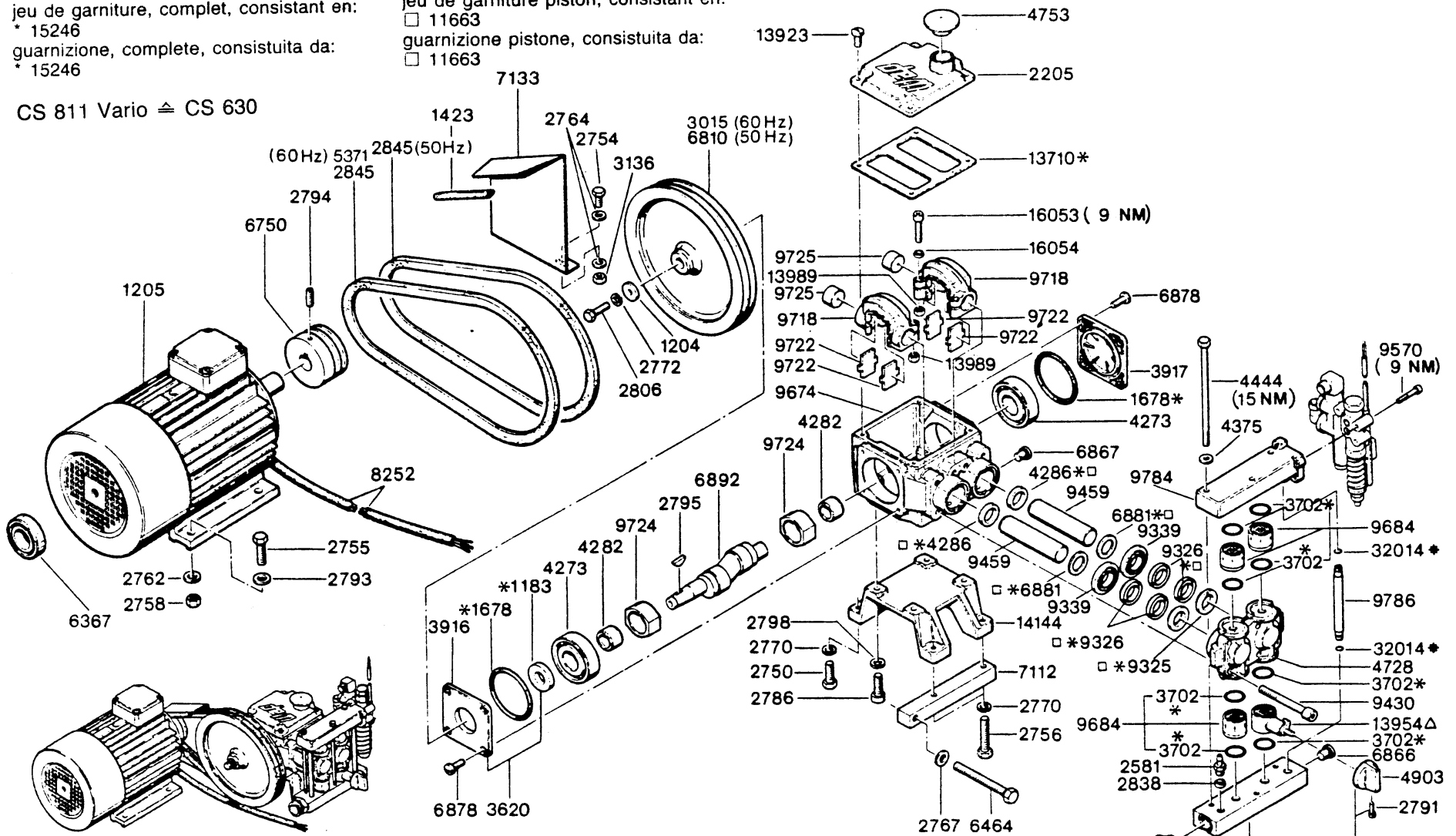

Ventileinsatz 17967 für Regulierventil (13954)
 coeur de soupape 17967 pour soupape (13954)
 cuore della valvola 17967 per valvola (13954)

Ventileinsatz 11657 für 1 Ventil (9684)
 coeur de soupape 11657 pour 1 soupape (9684)
 cuore della valvola 11657 per valvola (9684)

Δ nicht bei CS 603

Wap® CS 603 / 630

Dichtungssatz kpl. bestehend aus:

* 15151

jeu de garniture, complet, consistant en:

* 15151

guarnizione, complete, consistuita da:

* 15151

CS 811 Vario ≙ CS 630

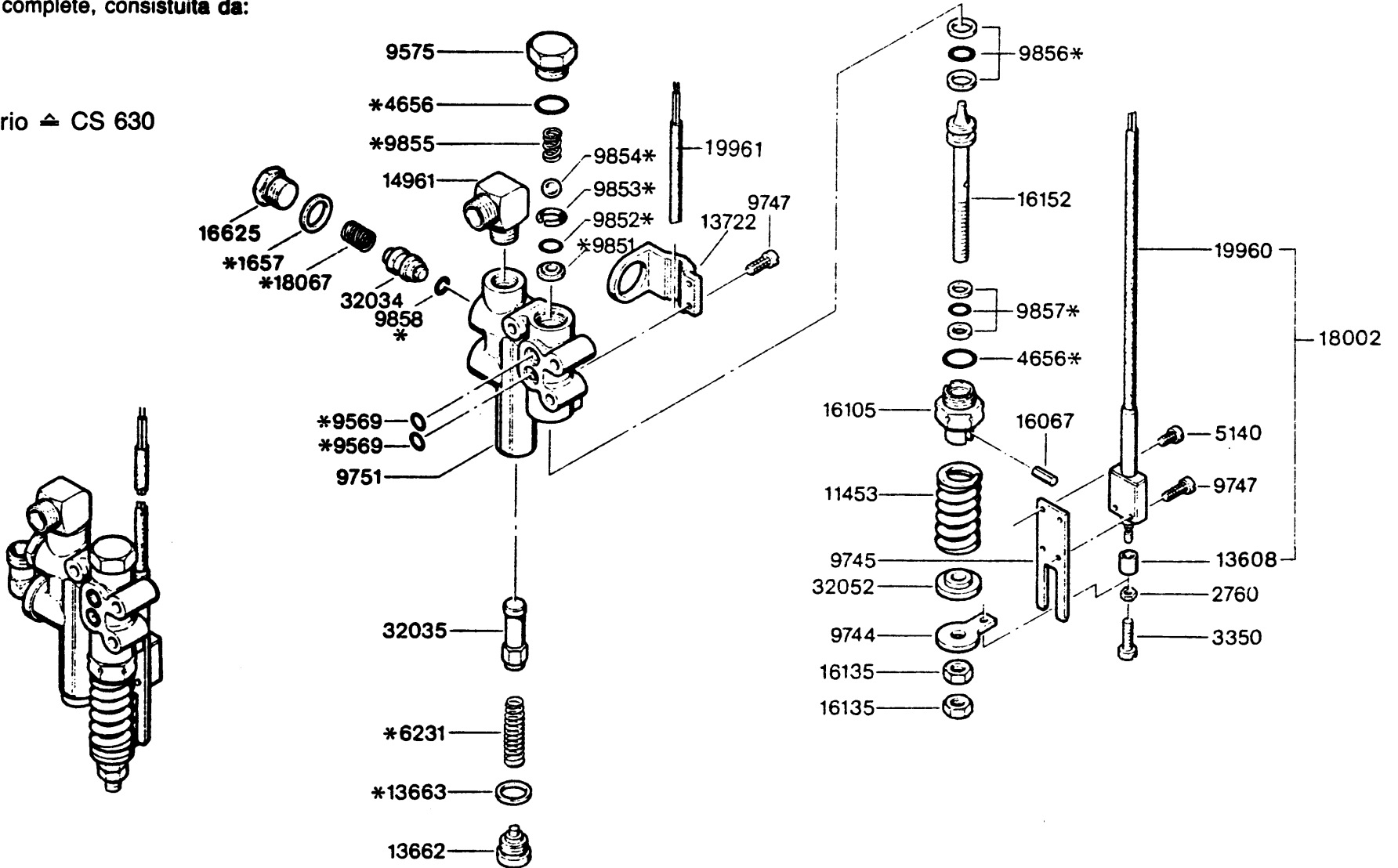

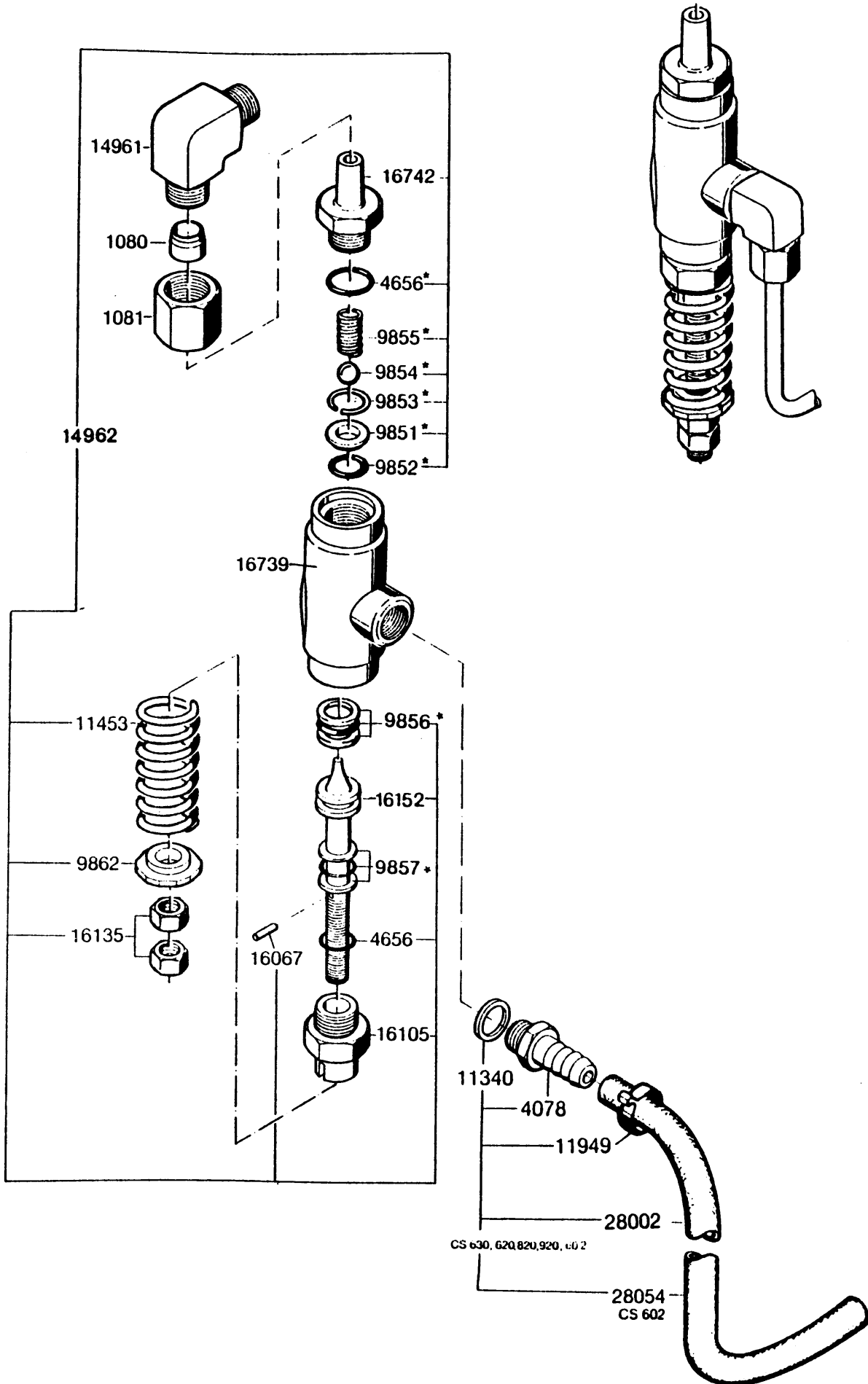

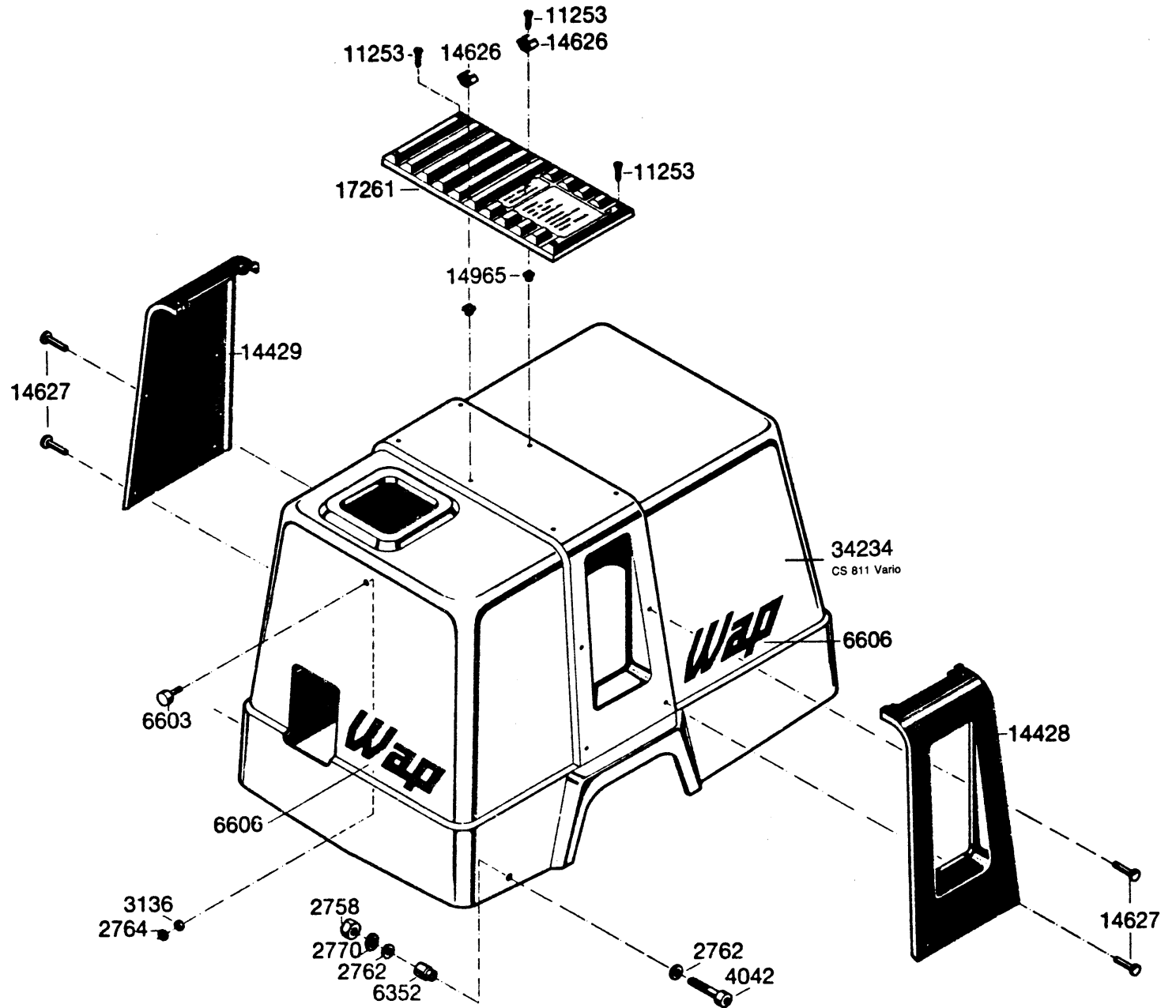

HD-Zubehör

HD-Düsen siehe Düsentabelle

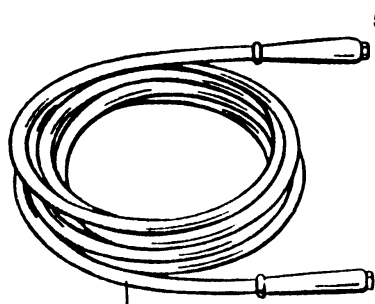
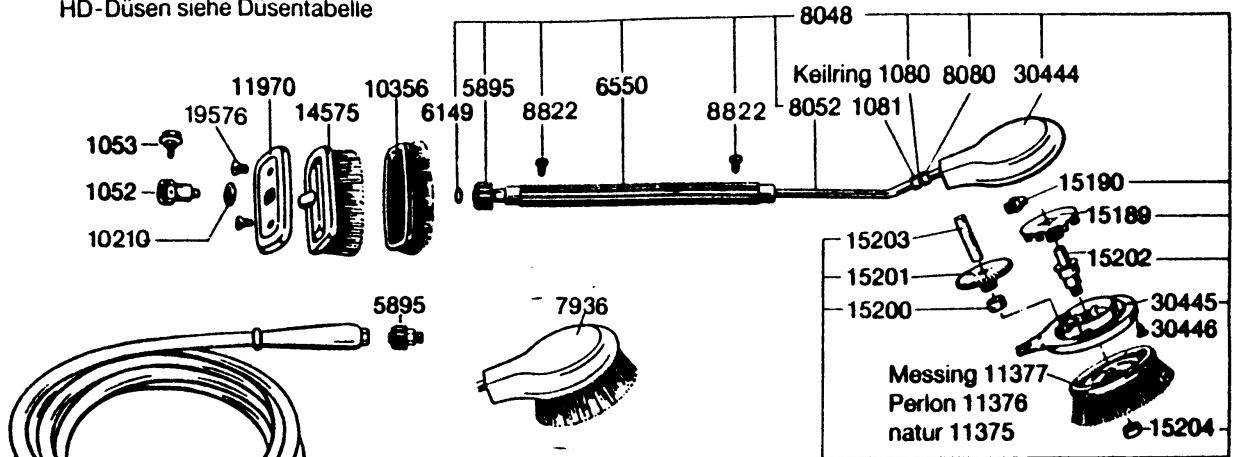

- 8626 NW 6 x 10 m
- 14987 NW 8 x 10 m
- 8232 NW 10 x 50 m (SL)
- 8233 NW 10 x 15 m (SL)
- 5404 NW 10 x 10 m (SL)
- 7826 NW 10 x 50 m
- 1476 NW 10 x 20 m
- 1475 NW 10 x 15 m
- 1473 NW 10 x 10 m

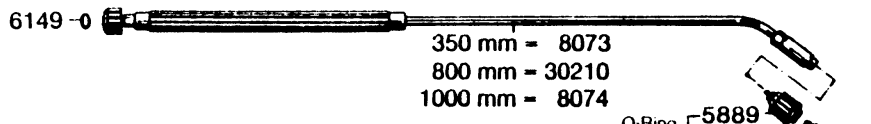
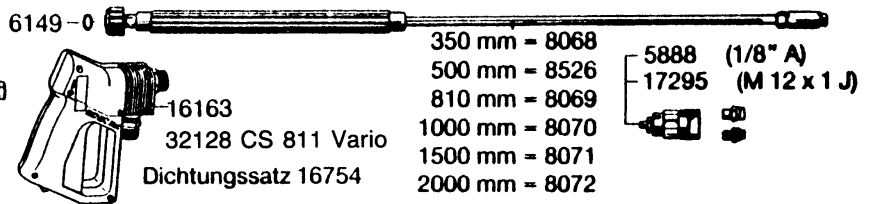

- Ø 0,9 = 15834
- Ø 1,0 = 11328
- Ø 1,1 = 4875
- Ø 1,2 = 5567
- Ø 1,4 = 5477

